

ASSEMBLY INSTRUCTION

HARDWARE LIST

NO	DESCRIPTION	QTY
8	BARREL NUT M6 X 13MM	10 PCS
19	M6 X 60MM JCBC SCREW BOLT	1 PC
20	M8 X 25MM DOWEL	12 PCS
35	M4 X 30MM CHIPBOARD SCREW	8 PCS
40	M4 ALLEN KEY	1 PC
42	PVC NAIL WITH PIN 5/8"	10 PCS
90	UNIVERSAL CAP 7102	5 PCS
181	M6 X 70MM JCBC SCREW BOLT	9 PCS

PARTS LIST

NO	DESCRIPTION	QTY
A	HEADBOARD	1
B	FOOTBOARD	1
C	SIDE RAIL	2
D	CENTER RAIL	1
E	SLAT	1 SET

CLEANING & CARE

General information : Do never put hot items on the surface tops! Empty furniture before moving and do not drag the furniture over the floor.

Maintenance : Clean with slightly wet moistened cloth, wipe dry immediately. Wipe off wetness at once. Not suited for humid locations. Avoid any abrasive detergents and product with ammonia / chemicals as these may cause damage, Avoid direct sunlight, Dust / wipe often with soft, non-abrasive cloth / duster.

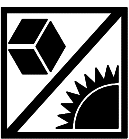

AVOID DIRECT SUNLIGHT



WIPE WITH CLEAN CLOTH



AVOID HOT ITEM



AVOID SOLVENTS

PARTS LIST

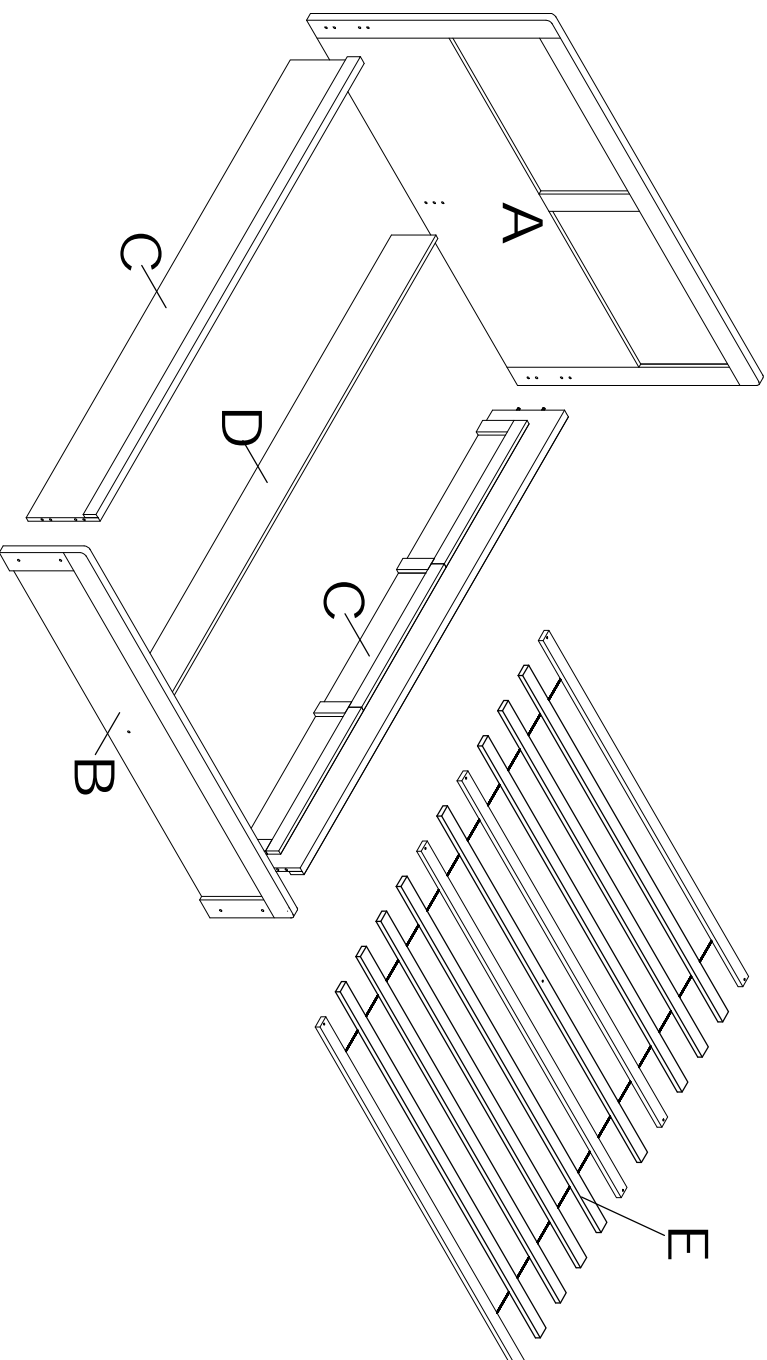

COMPLETED
ASSEMBLY

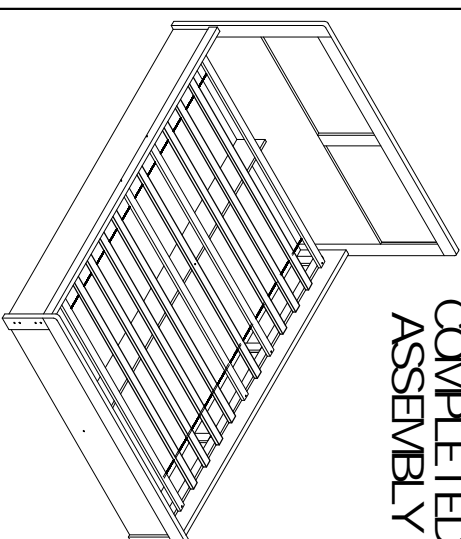

ASSEMBLY INSTRUCTION

STEP 1

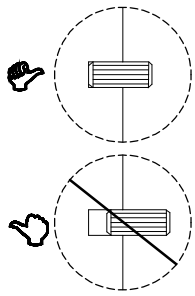

20 (X12)

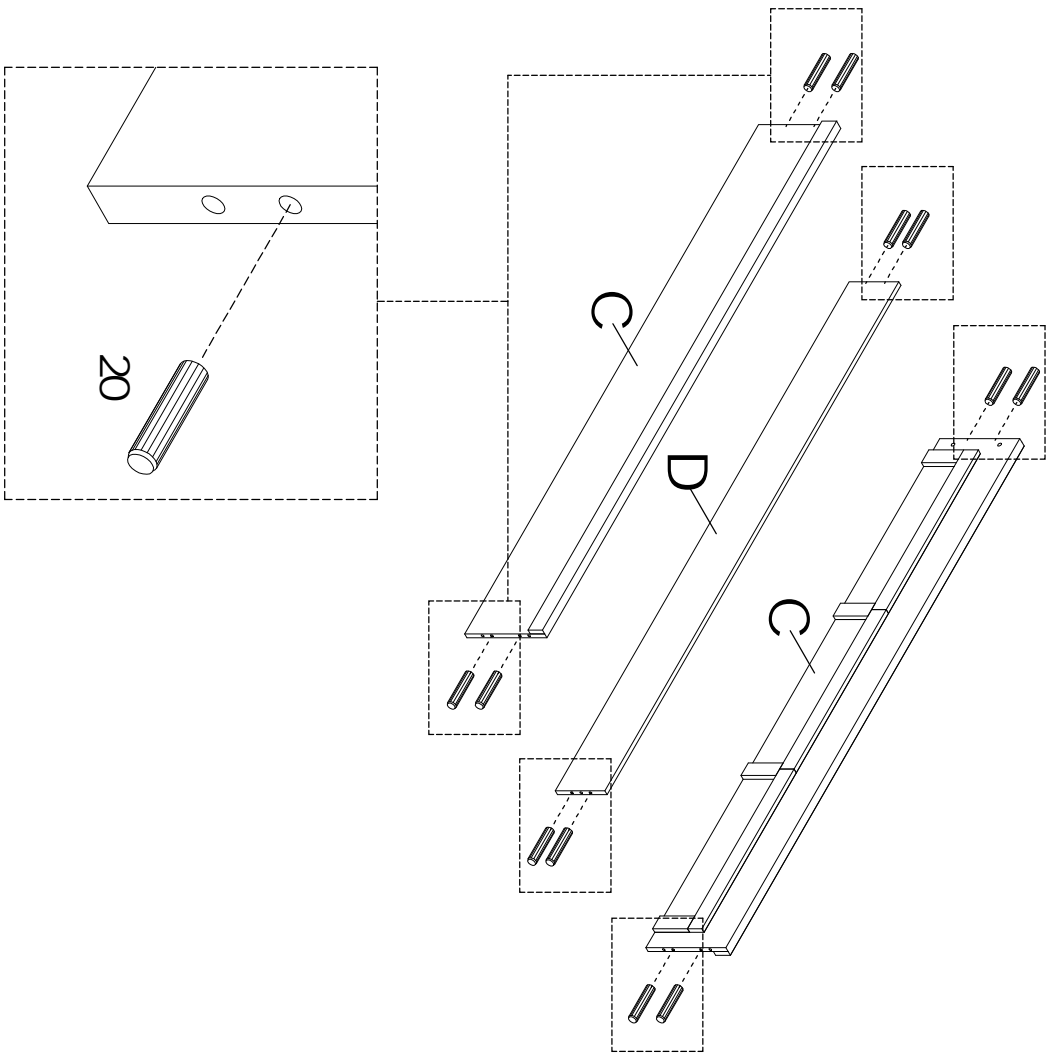
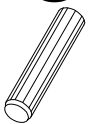

STEP 2



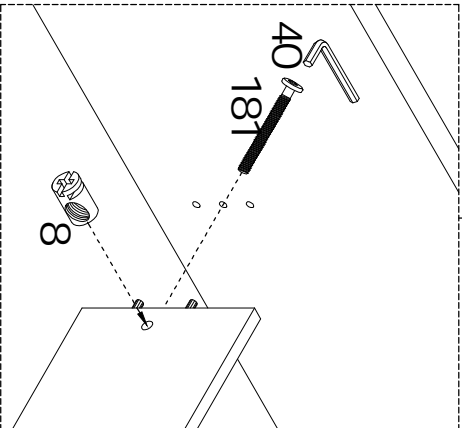
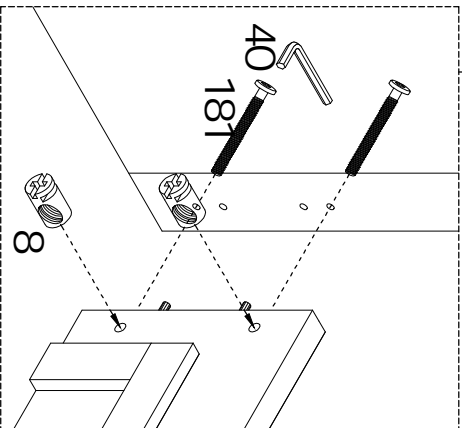
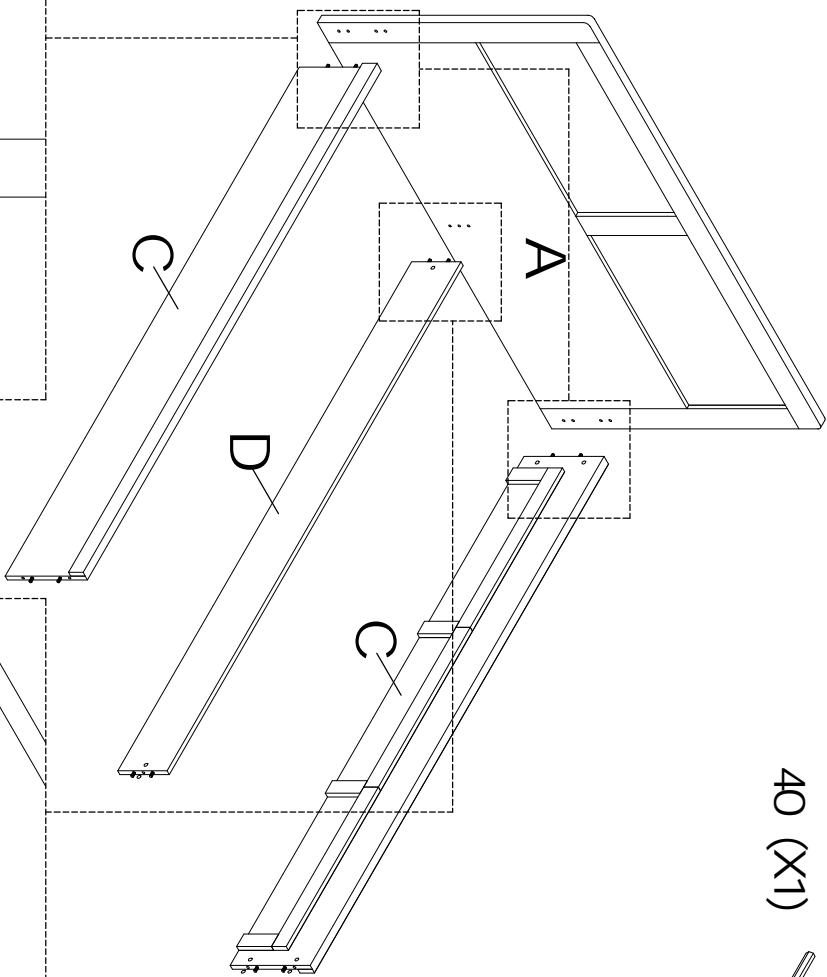

- 8 (X5)
- 181 (X5)
- 40 (X1)

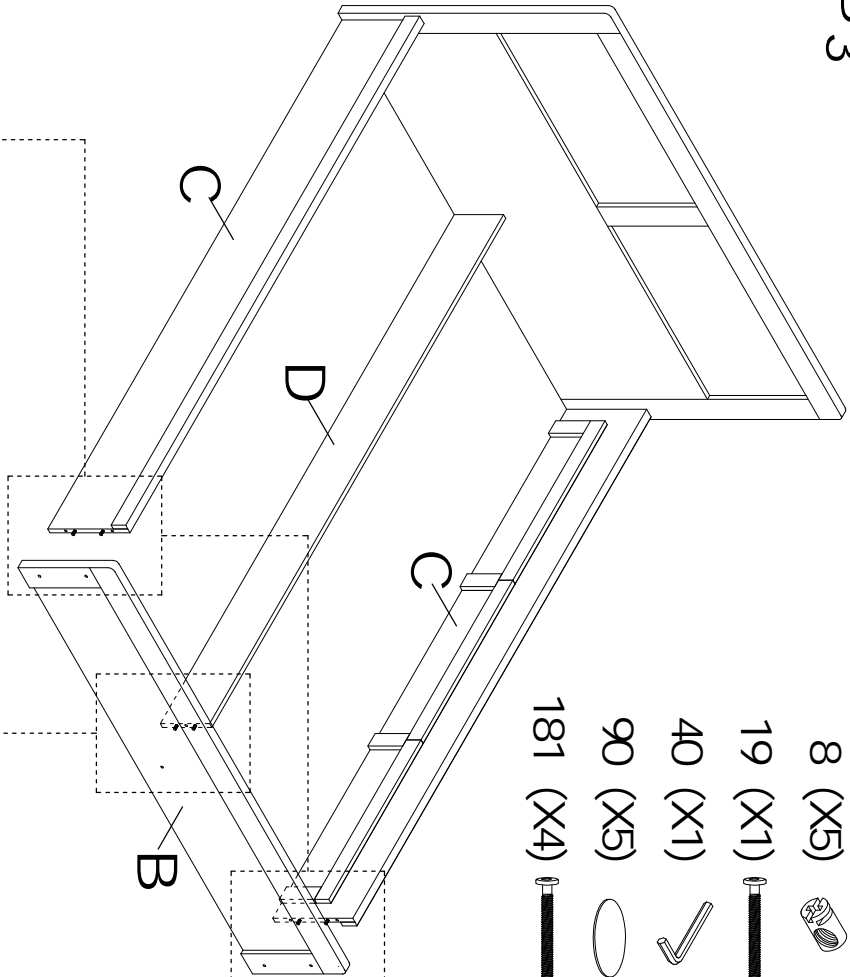

ASSEMBLY INSTRUCTION

STEP 3



- 8 (X5) 
- 19 (X1) 
- 40 (X1) 
- 90 (X5) 
- 181 (X4) 

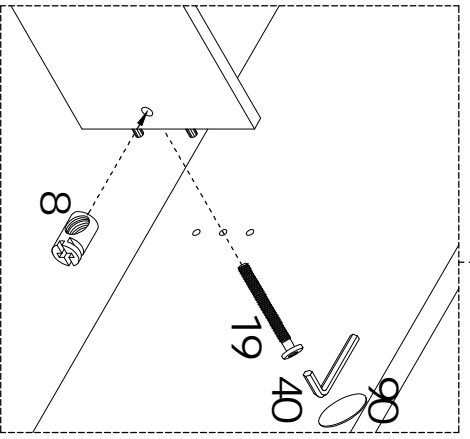
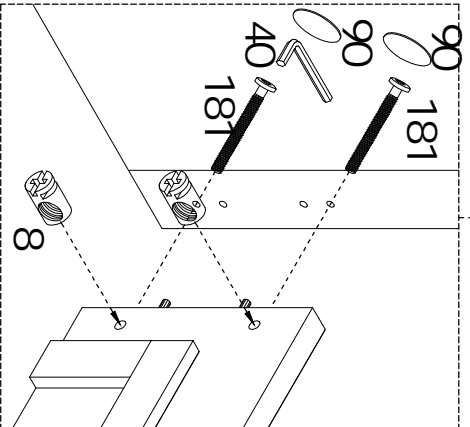

STEP 4

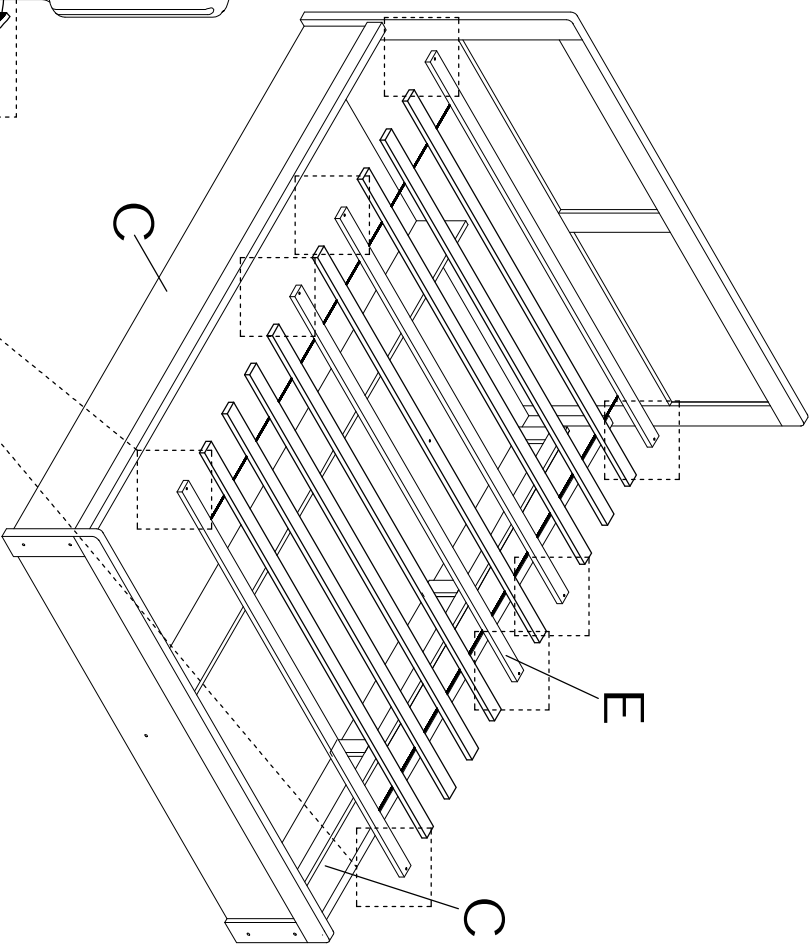

- 35 (X8) 

