

QUEEN BED

ASSEMBLY INSTRUCTION

HARDWARE LIST

NO	DESCRIPTION	QTY
19	M6 X 60MM JCBC SCREW (RB)	2 PCS
132	M6 X 80MM JCBC SCREW (RB)	8 PCS
8	M6 X 13MM BARREL NUT	10 PCS
35	M4 X 30MM CHIPBOARD SCREW	8 PCS
20	M8 X 25MM DOWEL	12 PCS
90	UNIVERSAL CAP	5 PCS
40	M4 ALLEN KEY	1 PC
42	5/8" PVC NAIL WITH PIN	15 PCS

PARTS LIST

NO	DESCRIPTION	QTY
A	HEAD BOARD PANEL	1 PC
B	FOOT BOARD PANEL	1 PC
C	SIDE RAIL PANEL	2 PCS
D	SLAT BASE (with hole 4 pcs, without hole 8 pcs = 12 pcs)	1 SET
E	CENTER RAIL	1 PC

CLEANING & CARE

General information : Do never put hot items on the surface tops! Empty furniture before moving and do not drag the furniture over the floor.

Maintenance : Clean with slightly wet moistened cloth, wipe dry immediately.

Wipe off wetness at once. Not suited for humid locations. Avoid any abrasive

detergents and product with ammonia / chemicals as these may cause damage.

Avoid direct sunlight, Dust / wipe often with soft, non-abrasive cloth / duster.

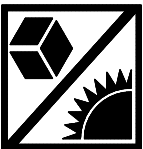

AVOID DIRECT SUNLIGHT



WIPE WITH CLEAN CLOTH

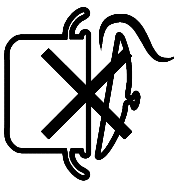

AVOID HOT ITEM



AVOID SOLVENTS

EXPLODE VIEW

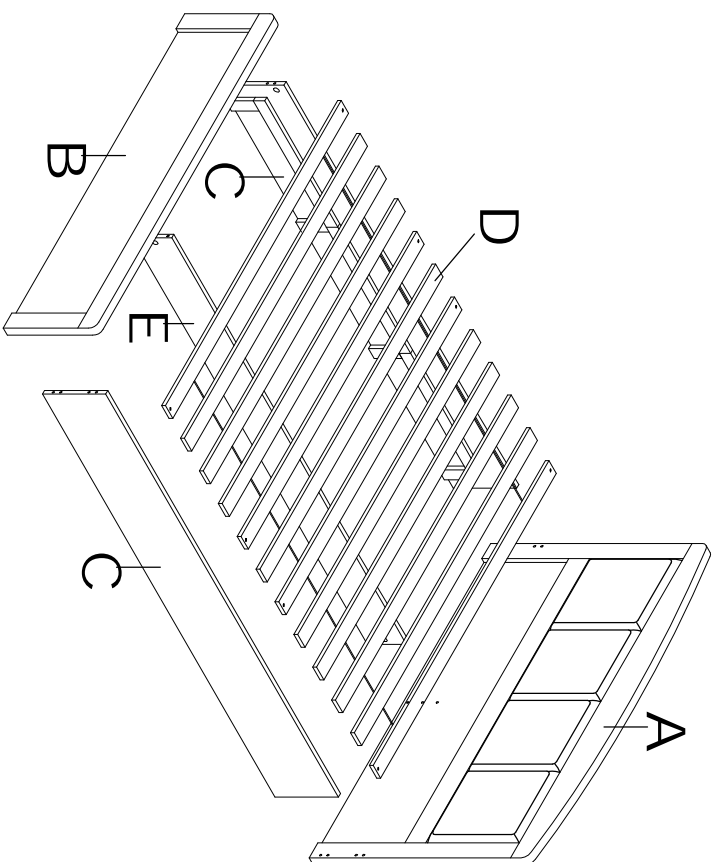

DETAIL

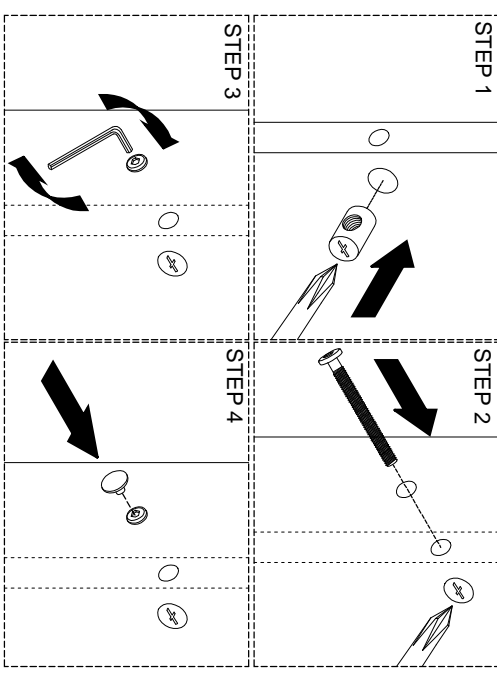

STEP 1

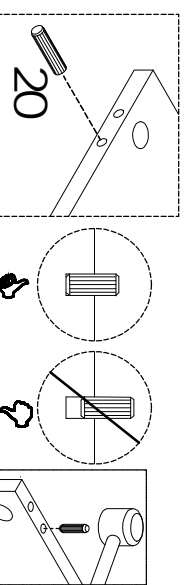

20 (X12) 

STEP 2

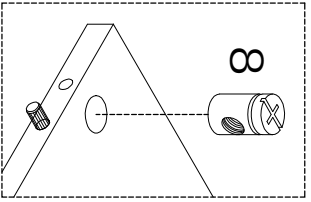

8 (X10) 

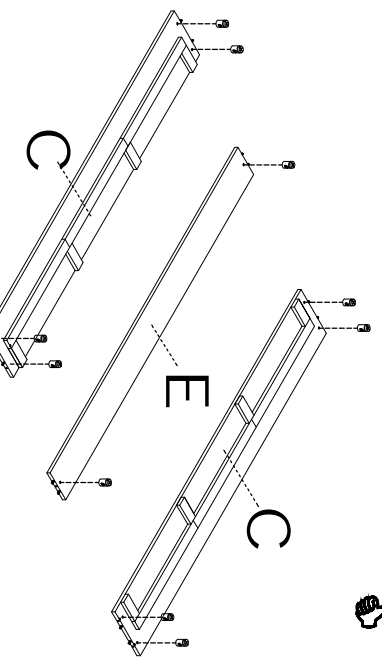
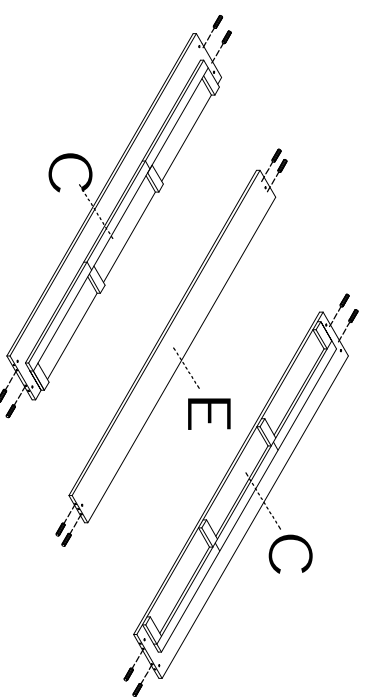



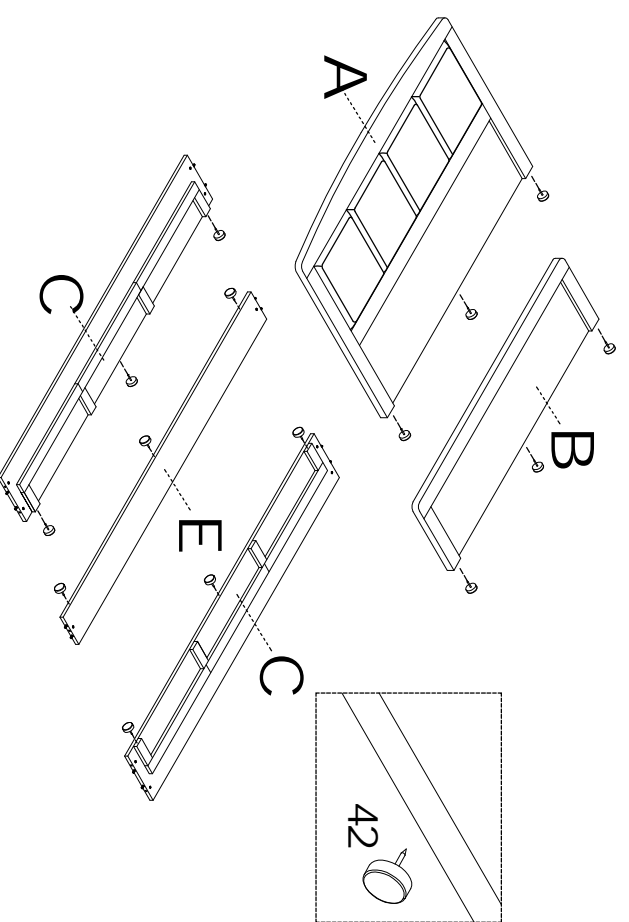

STEP 3

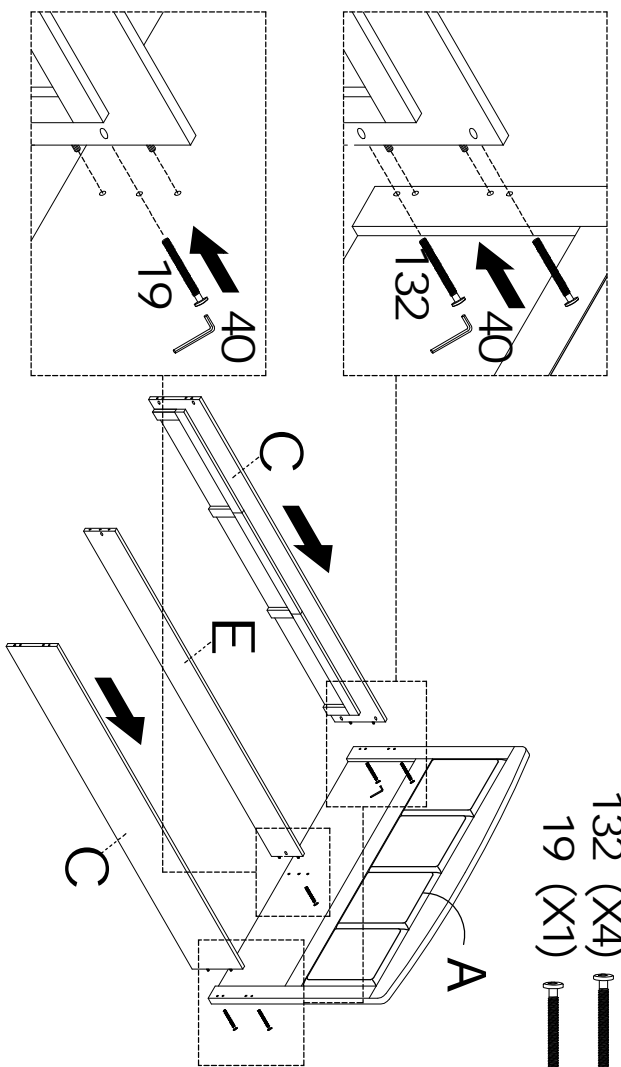

42 (X15) 

STEP 4



40 (X1) 
 132 (X4) 
 19 (X1) 

STEP 5

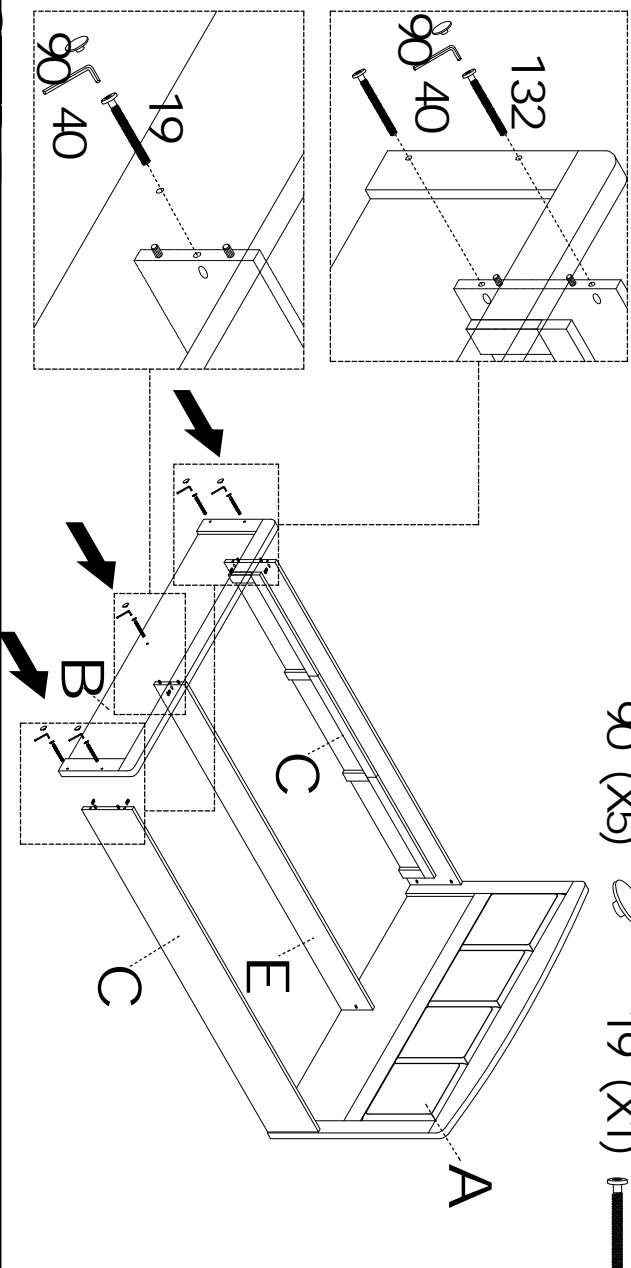

STEP 6

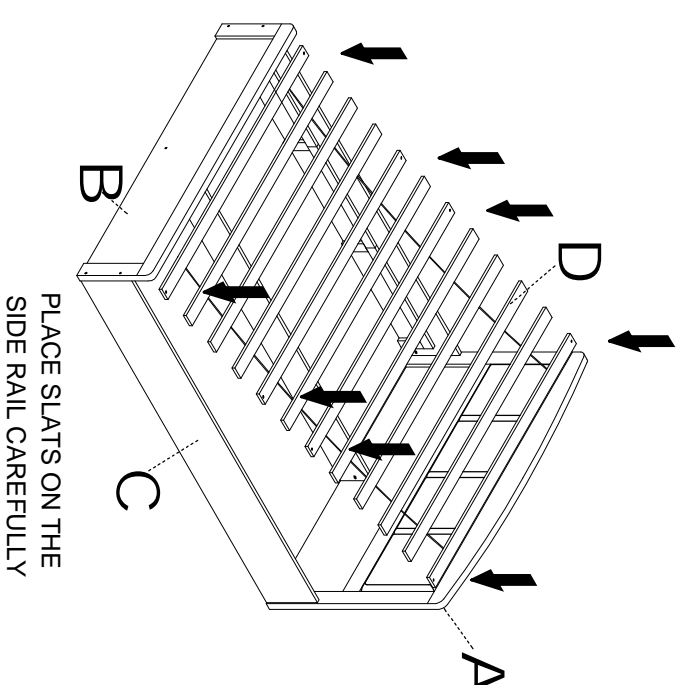

STEP 7

FIX THE END OF SLATS TO TOP OF SIDE RAIL CLEAT (INNER SIDE RAILS)

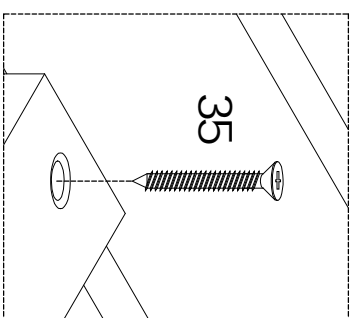
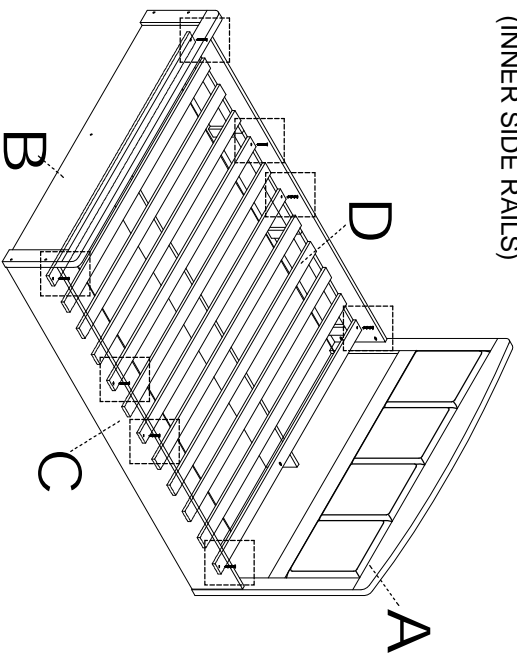

35 (X8) 

COMPLETED ASSEMBLY

